

PERFORMANCE RANGE

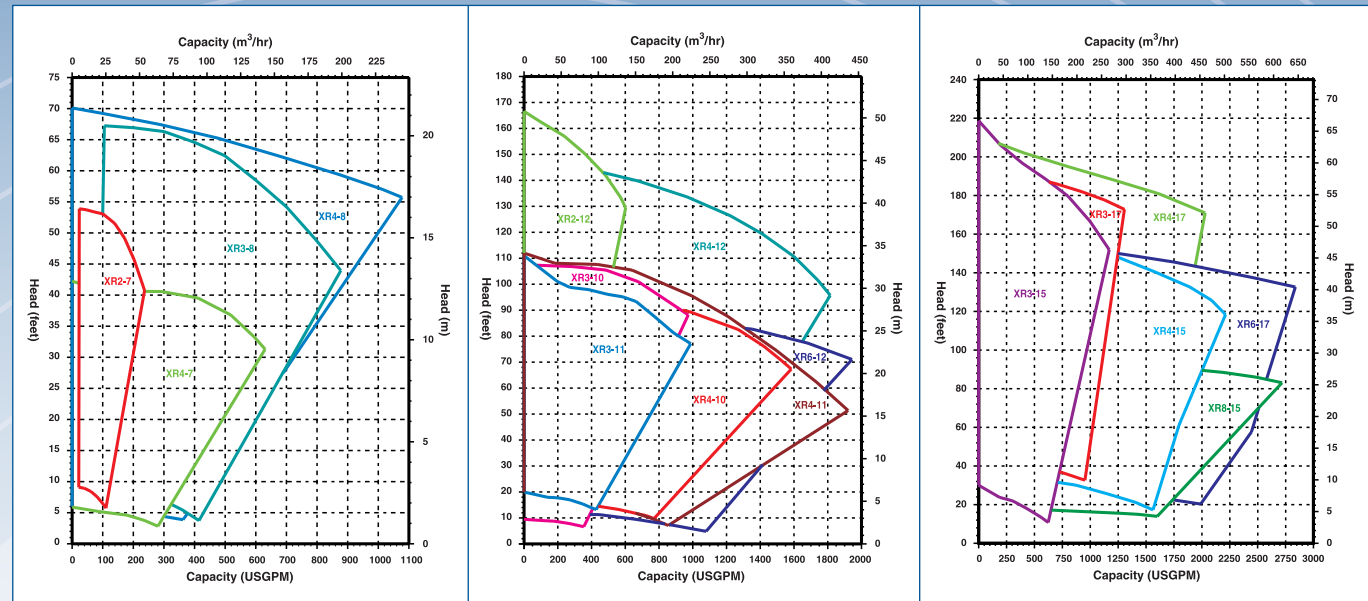

DRIVE CONFIGURATIONS

Vertical Cantilever Pump

No submerged bearings or close tolerances for operation in sumps that contain abrasive solids or other difficult to handle fluids.

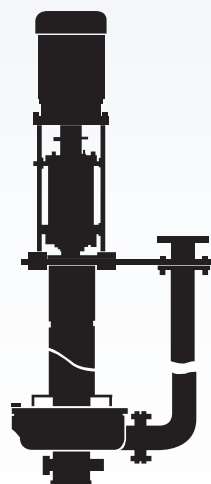

Submersible

For totally submerged operation.

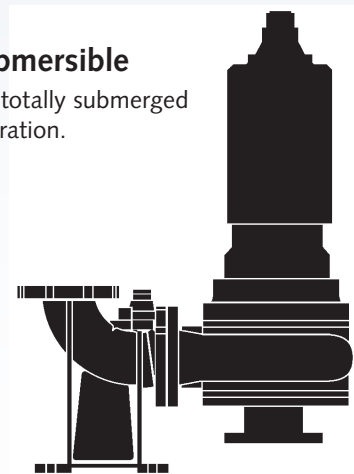

Vertical Dry Pit

For mounting outside of tanks.



Direct Drive

Motor directly coupled to the pump utilizing a spacer type coupling for back pull-out convenience. Hard metal impellers can be trimmed to size.

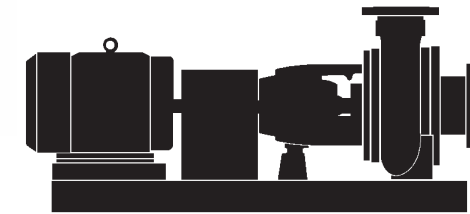

V-Belt Drive

Standard side by side mount or overhead mounting of motor. Base design permits easy access to the pump for service and back pull-out.

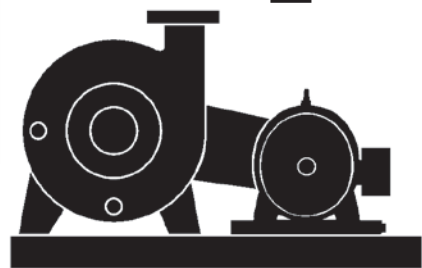

DIRECT DRIVE

Dimensions shown in shaded areas are millimeters, others are in inches.

NOT FOR CONSTRUCTION USE.

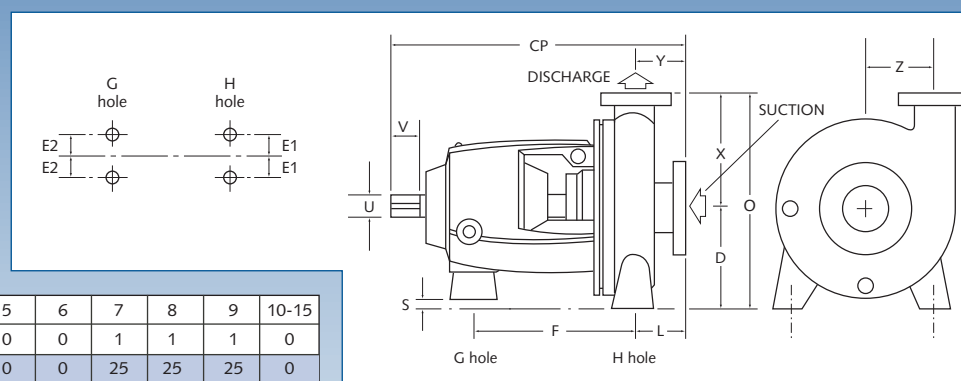

Item No.	1	2	3	4	5	6	7	8	9	10-15
DIM. 'S' Inch	1.37	1.37	2.25	2.25	0	0	1	1	1	0
mm.	35	35	55	55	0	0	25	25	25	0

ITEM	XR, R, RS MODEL NO.	FRAME GROUP	DISCHARGE x SUCTION x IMPELLER DIA.	CP	D	E ₁	E ₂	F	G	H	L	U		O	V	X	Y	Z	WT. Lb. Kg.
												DIA.	KEYWAY						
1	2-7	1	2 x 3 x 7	20.56	6.7	4.75	0	10.37	.62	.75	3.75	1.06	.25 x .12	14.2	2	7.5	3.75	3.75	165
			50 x 80 x 180	520	170	120	0	265	16	18	95	27	6.4 x 3.2	361	50	190	95	95	75
			4 x 6 x 7	22.75	6.7	4.75	0	11.37	.62	.75	4.94	1.06	.25 x .12	15	2	8.25	4.94	4.12	195
			100 x 150 x 180	580	170	120	0	290	16	18	125	27	6.4 x 3.2	381	50	210	125	105	89
2	4-7	1	3 x 4 x 8.5	22.31	7.5	4.75	0	11.12	.62	.75	4.75	1.06	.25 x .12	16.37	2	8.87	4.75	3.94	210
			80 x 100 x 215	565	190	120	0	280	16	18	120	27	6.4 x 3.2	415	50	225	120	100	95
			4 x 6 x 8.5	23.31	7.5	4.75	0	11.56	.62	.75	5.31	1.06	.25 x .12	16.56	2	9.06	5.31	4.5	225
			100 x 150 x 215	590	190	120	0	295	16	18	135	27	6.4 x 3.2	420	50	230	135	115	102
3	3-8	2	3 x 4 x 10	30.37	10	6.5	3.75	17	.62	.87	5.12	1.87	.5 x .25	21	3.54	11.0	5.12	5.12	470
			80 x 100 x 260	770	255	165	95	430	16	22	130	47.6	12.7 x 6.4	535	90	280	130	130	214
			4 x 6 x 10	31.06	10	6.5	3.75	17.37	.62	.87	5.5	1.87	.5 x .25	21	3.54	11.0	5.5	5.12	510
			100 x 150 x 260	790	255	165	95	440	16	22	140	47.6	12.7 x 6.4	535	90	280	140	130	232
4	4-8	2	2 x 3 x 12.5	28.75	11	7.12	3.75	16	.62	.87	4.5	1.87	.5 x .25	22.62	3.54	11.62	4.5	7.12	520
			50 x 80 x 315	730	280	180	95	405	16	22	115	47.6	12.7 x 6.4	575	90	295	115	180	236
			4 x 6 x 12.5	31.25	11	7.12	3.75	17.37	.62	.87	5.69	1.87	.5 x .25	23.19	3.54	12.19	5.69	6.31	560
			100 x 150 x 315	795	280	180	95	440	16	22	145	47.6	12.7 x 6.4	590	90	310	145	160	255
5	3-11	3	6 x 8 x 12.5	33.93	11	7.12	3.75	19.00	.62	.87	6.69	1.87	.5 x .25	23.62	3.54	12.62	6.69	6.31	600
			150 x 200 x 315	860	280	180	95	485	16	22	170	47.6	12.7 x 6.4	600	90	320	170	160	272
			3 x 4 x 15	37.81	14.5	7.87	4.5	23.25	1.0	1.0	4.5	2.87	.75 x .37	28.25	5.5	13.75	4.5	7.87	820
			80 x 100 x 380	960	370	200	115	590	25	25	115	73	19 x 9.5	720	140	350	115	200	373
6	4-11	3	4 x 6 x 15	39.12	14.5	7.87	4.5	23.81	1.0	1.0	5.44	2.87	.75 x .37	28.69	5.5	14.19	5.44	7.5	900
			100 x 150 x 380	995	370	200	115	605	25	25	140	73	19 x 9.5	730	140	360	140	190	409
			8 x 10 x 15	43.69	14.5	7.87	4.5	25.75	1.0	1.0	8.06	2.87	.75 x .37	29.62	5.5	15.12	8.06	7.5	1010
			200 x 250 x 380	1110	370	200	115	655	25	25	205	73	19 x 9.5	755	140	385	205	190	460
7	2-12	3	3 x 4 x 17	38.37	14.5	8.87	4.5	23.62	1.0	1.0	4.87	2.87	.75 x .37	28.69	5.5	14.19	4.87	8.87	980
			80 x 100 x 440	975	370	225	115	600	25	25	125	73	19 x 9.5	730	140	360	125	225	446
			4 x 6 x 17	39.31	14.5	8.87	4.5	24	1.0	1.0	5.44	2.87	.75 x .37	29.06	5.5	14.56	5.44	8.50	1005
			100 x 150 x 440	1000	370	225	115	610	25	25	140	73	19 x 9.5	740	140	370	140	215	457
8	4-12	3	6 x 8 x 17	43.50	14.5	8.87	4.5	25.50	1.0	1.0	8.12	2.87	.75 x .37	30.62	5.5	16.12	8.12	8.50	1200
			150 x 200 x 440	1105	370	225	115	648	25	25	206	73	19 x 9.5	778	140	410	206	215	545

*Weights are for Model "R" BARE PUMPS only.



WATER > PROCESS > INNOVATION

Unit 4 & 6, 68 Railway Crescent, Lisarow, NSW 2250
Ph: 02 4328 1066
tankenviro.com.au



haywardgordon.com
info@haywardgordon.com

06/15 1.5M
Printed in Canada



TORUS® RECESSED IMPELLER VORTEX PUMPS



The ideal solution for pumping fluids containing large solids, abrasives, delicate crystals, fibres, stringy materials and gasses.

www.haywardgordon.com



PUMPS

TORUS RECESSED IMPELLER SOLID HANDLING PUMPS

What They Are

A vortex or recessed impeller pump is a centrifugal pump which has, as the name implies, a semi-open impeller recessed into the rear section of the volute, out of the path of the solids being pumped. This impeller uses about 15 percent of the fluid being pumped to create a torus or vortex thus adding energy to the pumped fluid-solids, very similar in action to one half of a fluid coupling.

State-of-the-Art TORUS pumps are a unique design featuring a low cost wear ring in the "R" and "XR" series that takes the brunt of abrasive wear, saving more expensive parts. They are simple in design with large open clearances and mining type "clamped" volutes. Their back pull-out feature, keyed impellers, interchangeability of parts between series and sizes, and heavy duty ruggedness keep maintenance, inventory and operating costs low.

What They Do

TORUS vortex pumps are designed to efficiently handle (a) large soft solids that will pass the pump discharge port (up to 8"); (b) long stringy or fibrous materials that "wind up" in conventional non-clog pumps; (c) delicate, crystalline or other friable solids with minimum degradation; (d) slurries or sludges, etc. with high gas entrainment (up to 20 percent by volume) without vapour locking; (e) large soft solids, sludges, etc. mixed with varying amounts of abrasive or highly abrasive solids.

From waste treatment grit to coal slurries, slurried bones to aerated paper stock, there is a TORUS pump designed for your special application.

"XR" SERIES TORUS is the extra heavy duty TORUS vortex pump. This series is designed to handle heavy, highly abrasive slurries in addition to the pumping applications described for the "R" series. These pumps feature extra heavy casings, impellers and sacrificial wear rings. The 16 "XR" models can also be made in any castable metal but are usually manufactured in abrasion resistant metals having a hardness up to 750 Brinell.

"R" SERIES TORUS is the standard model with heavy wet-end parts including a sacrificial back plate and optional wear ring. All 16 sizes can be made in any castable metal including iron, hard metals and stainless alloys. "R" series pumps are used for passing solids up to 8" diameter, medium abrasive slurries, long stringy materials, delicate or crystalline solids, and fluids with high gas entrainment.

"RS" SERIES TORUS, with 16 pump models, has no wear ring. These pumps will efficiently handle large, stringy or delicate solids and gaseous fluids. This series has the highest efficiency of vortex pumps and is most often supplied in castable stainless alloys for pumping solids in corrosive fluids.

Size for size the wet-end parts of each series are interchangeable with all other series "R", "XR" or "RS". This important feature allows field retrofitting if unexpected abrasive or corrosive conditions are found.

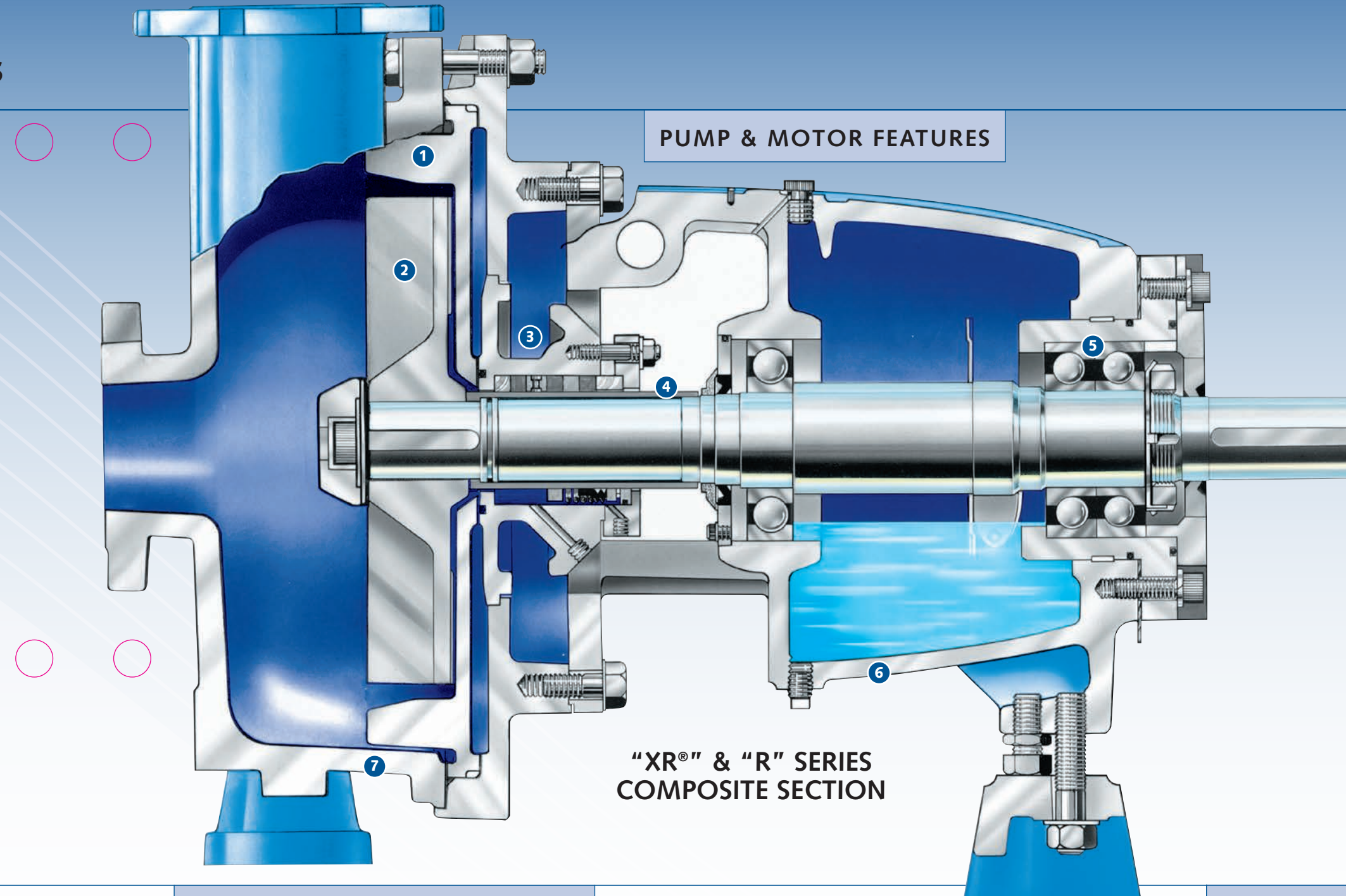

- 1 Wear Rings**
"R" and "XR" models feature a unique, low cost, sacrificial wear ring and back plate. The "XR" wear rings are made extra heavy in hard metals to absorb the wear under extremely abrasive conditions.
- 2 Impeller**
The fully recessed impeller allows clear passage of all solids that will pass the casing discharge port and easily handles large, stringy, delicate, sticky or abrasive solids without clogging. Positive eductor back vanes maintain low pressure at the packing or mechanical seal.
Because the impeller is concentric in the casing, it virtually eliminates radial loads making the TORUS wet-ends an excellent choice for use in vertical cantilever pumps. All impellers including those of hard metal construction such as Super Ni-Hard are machined and positively keyed to the shaft. No babbitt is used. The straight vane design is also ideal for field repair.
- 3 Stuffing Box**
The generous sized stuffing box is highly accessible for easy adjustment and maintenance, especially if advantage is taken of the back pull-out feature. It will accommodate any packing and virtually all single or double mechanical seals in U.S. or metric sizes.
- 4 Shafts & Sleeves**
Shafts are one piece, extra heavy designed to minimize deflections. Replaceable hook-type sleeves, keyed to the shaft, are available in hardened 410 stainless steel, type 316 SS or Hastelloy "C" as standards with optional alloys or hard coatings such as Tung-car or ceramic.
- 5 Bearings**
Bearings are sized for a minimum L₁₀ life of over 100,000 hours at maximum load conditions. Oil, oil mist or grease lubrication is available.
- 6 Powerframes**
For maximum standardization and minimum inventory cost, all TORUS vortex pumps consisting of 48 models and sizes are mounted on just 3 standard, heavy duty powerframes. The large oil sump and extra large radiating surfaces allow pumping of higher temperature fluids without powerframe cooling and maintains lower bearing temperatures.
- 7 Casing**
The one-piece casing is made in a variety of metallurgies and thickness to handle most fluids with solids up to 8" diameter. The design provides clear passage of any solid the size of the discharge opening. The casing is solidly foot-mounted allowing true back pull-out and protection against overhung piping loads which cause undue shaft and seal deflections.

OTHER DESIGN FEATURES

BACK-PULLOUT Like all modern process pumps, each TORUS series features solid foot-mounted casings for protection against distortion of shafts and seals due to pipe loads and stresses found in the older, overhung, cantilevered designs. When directly driven with a spacer coupling or v-belt driven, the TORUS foot-mounted casing allows true back-pullout of the entire rotating assembly without disconnecting piping or motor. By carrying a spare rotating assembly, pump down-time can be kept to minutes and allows bench repair and testing of the removed assembly.

MATERIALS OF CONSTRUCTION

Fluid end castings are available in a wide range of cast irons, Ni-Hard and stainless steels. Wet-end parts can be combined in one pump to minimize cost and maximize wear life.

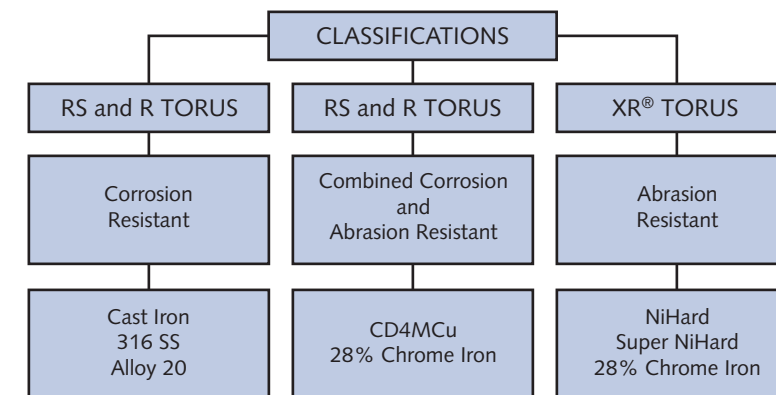

INDUSTRIES

Waste Treatment

Grit
Raw Sludge
Digested Sludge
Raw Sewage
Rags
Scum
Activated Sludge
Lime Slurry
Fly Ash

Mining & Metallurgical

Mine Water and Drainage
Tailings
Mill Scale

Water and Slag
Mill Flotation Circuits
Coal Slurries
Thickener Underflow
Limestone Slurry

Pulp & Paper

Wood Chips
Pulp Rejects
Black Liquor
Lime Slurry
Paper Stock
Aerated Stock
Green Liquor Dreg
Sludges

Food Processing & Agriculture

Potatoes in Water
Fish Offal
Bagasse
Liquid Manure
Cherries
Malted Barley
Bones
Vegetable Refuse
Shrimp
Lime Sludge
Chicken Wastes
Corn Cobs
Slaughterhouse Wastes

Chemical & Manufacturing

Crystal Suspensions
Rubber Crumb
Paint Sludge
Plant Sewage and Sludge
Tannery Fleshings
Fibre Slurry
Flocculants
Latex Resin Glue
Activated Carbon